

Stackable Steel Roll File

Assembly Instructions

for MODELS 629 and 630

CAUTION: READ STEPS (1) AND (2) BEFORE INSTALLING DOOR MAGNET.

- 1.** Roll file door can be reversed (if desired) by removing two hinge screws.

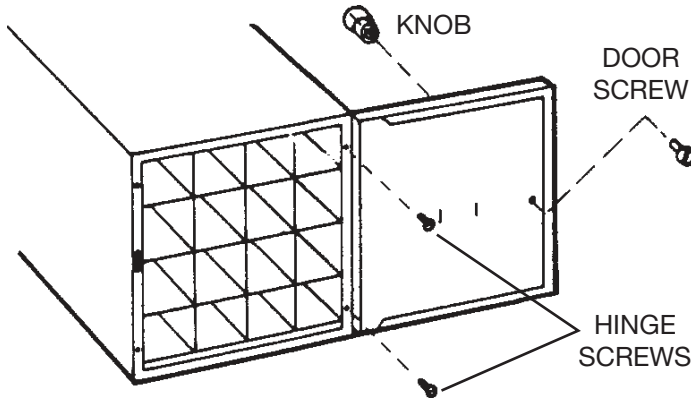

- 2.** Invert door and attach loosely with screws. Slide door up or down to center it. Tighten screws.

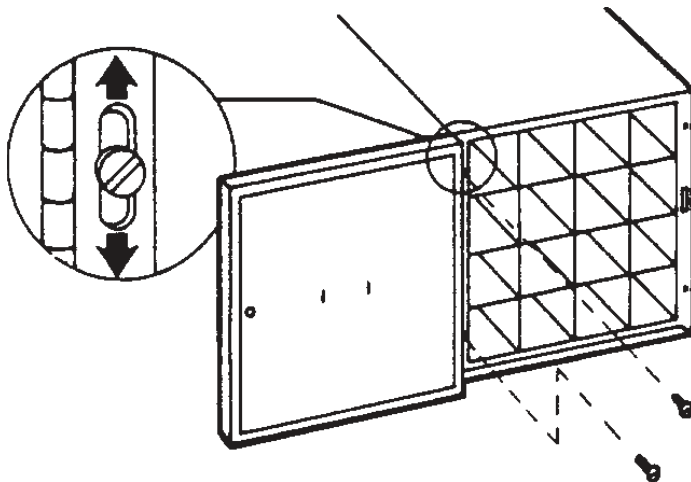

- 3.** Squeeze locking tabs (top and bottom) on magnet and press into door slot.

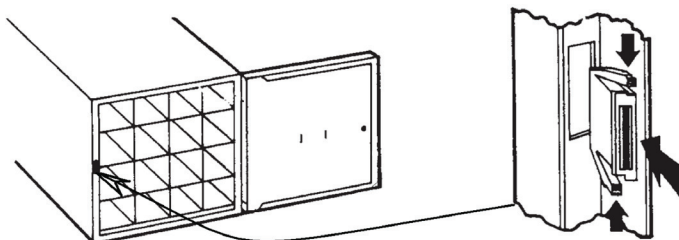

- 4.** Slide label holder tabs into slots 4 on front of door.

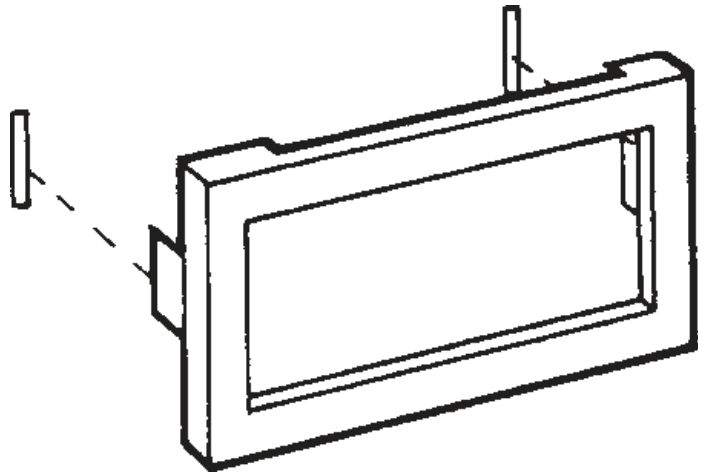

- 5.** Secure label holder by bending 5 tabs over on back.

