

ASSEMBLY INSTRUCTIONS SECURITY SORTER

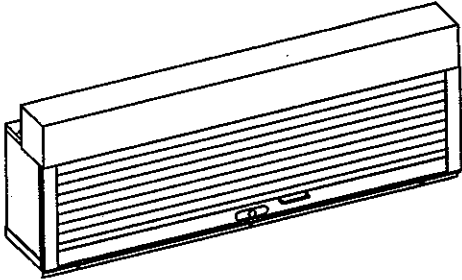

1 TIER

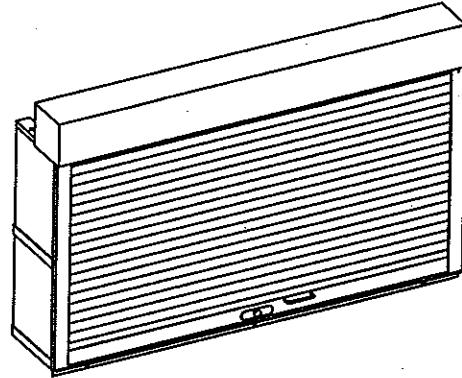

2 TIER

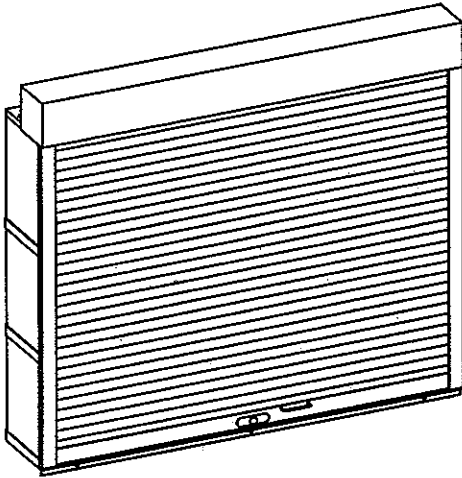

3 TIER

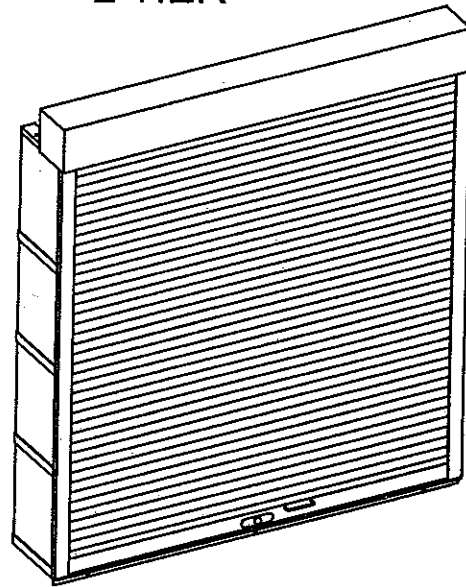

4 TIER

Unpack the contents of this shipment as soon as possible. Notify our customer service at once if any hidden damage is found after unpacking the cartons. Keep all the packing material for inspection. All claims for damages must be made within 15 days of delivery. Store each carton separately until assembly. Assemble each item individually to avoid confusion of hardware and pieces. Sort all the hardware using the Hardware Table and use the Diagram to identify each piece before assembly.

For more information or answers to your questions

Call toll free (800) 328-2962 (952) 403-0303

Website: www.charnstrom.com

Email: mail@charnstrom.com

Charnstrom Company, Shakopee, MN 55379

Note: The following instructions are for 1, 2, 3 and 4 Tier Security Sorters

HARDWARE TABLE:

1" Phillips Head Self Tapping Screw

Size	Quantity
1 Tier	11
2 Tier	15
3 Tier	19
4 Tier	23

Step 1

Attach each Top Rail to the Sorter Shell with 2 of the 1" Phillips Screws provided. The open side of the Rails should face inward. The Top Rails should be flush with the side, front and back of the Sorter (See Fig. 1).

Note: The Screws will not line up with the holes on top of the Sorter Shell.

The Sorter Shells are the same for multiple tier units. Simply choose one to be the Top Unit.

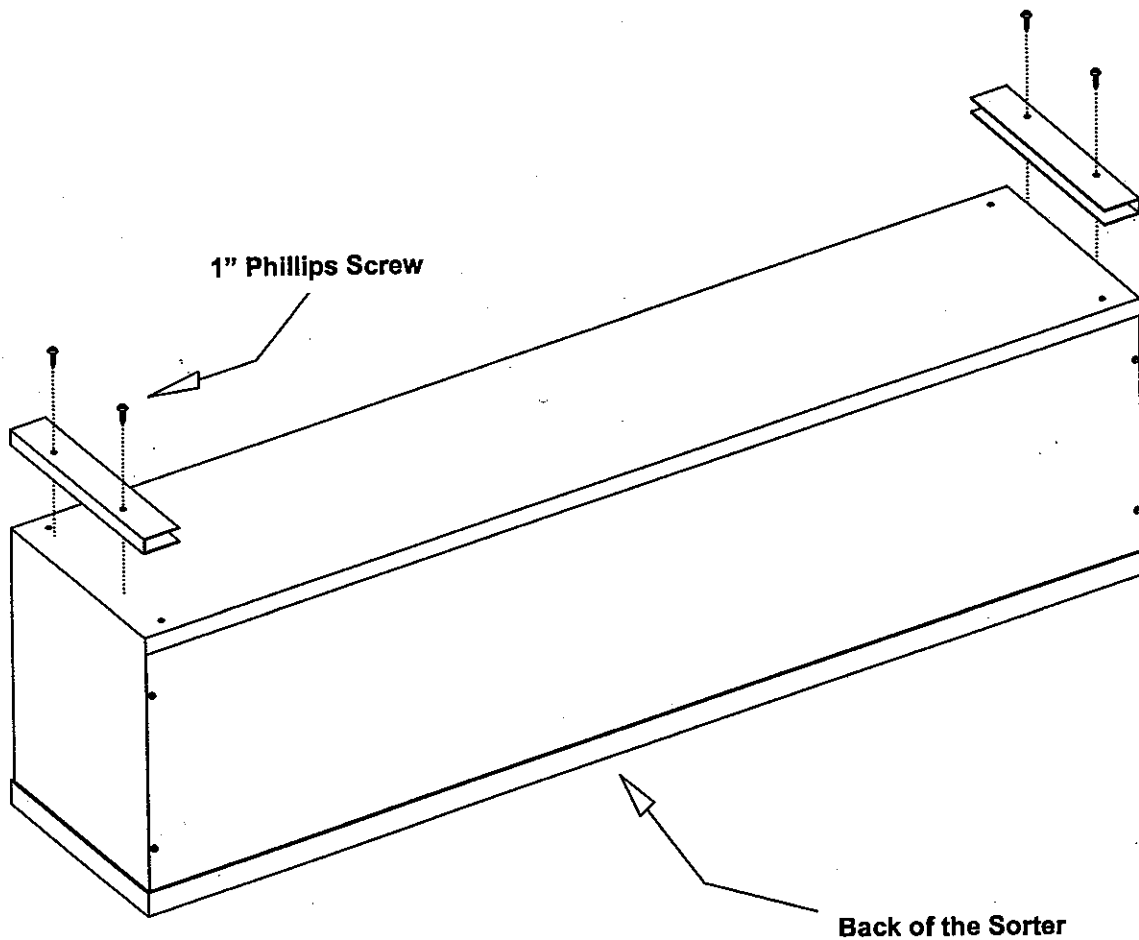

Figure 1

Note: Skip Step 2 if you are assembling a Single Tier Unit.

Step 2

Nest one of the Sorter Shells on top of the other Sorter Shell. Repeat procedure for multiple tiers (See Fig. 2).

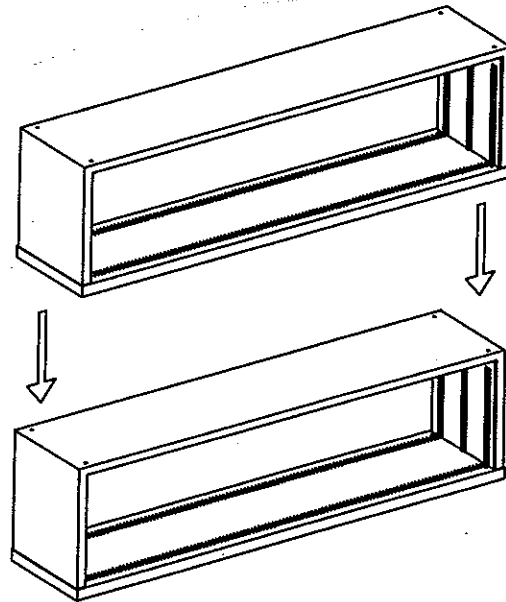

Figure 2

Step 3

Attach the Right Rail to the front of the Sorter Shell with the 1" Phillips Screws provided. The notch on the Rails should be positioned towards the top of the Sorter Shell. Repeat this procedure for the Left Rail.
Important: Start the Rails 1-3/8" up from the bottom Sorter (See Fig. 3).

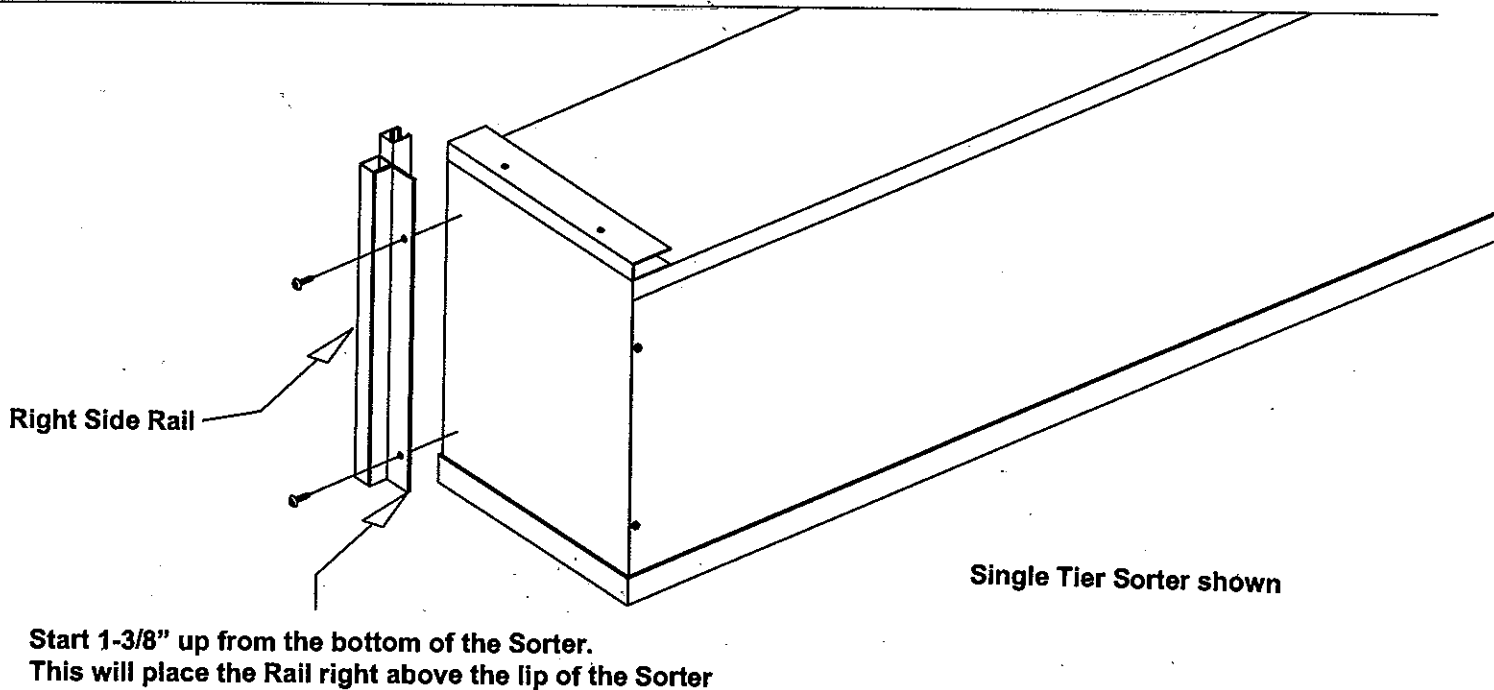

Figure 3

Step 4

Connect the Front Rail to the bottom Sorter with the 3 of the 1" Phillips Screws provided. The Front Rail must be positioned so that it rests against the Right & Left Rails (**See Fig. 4**).

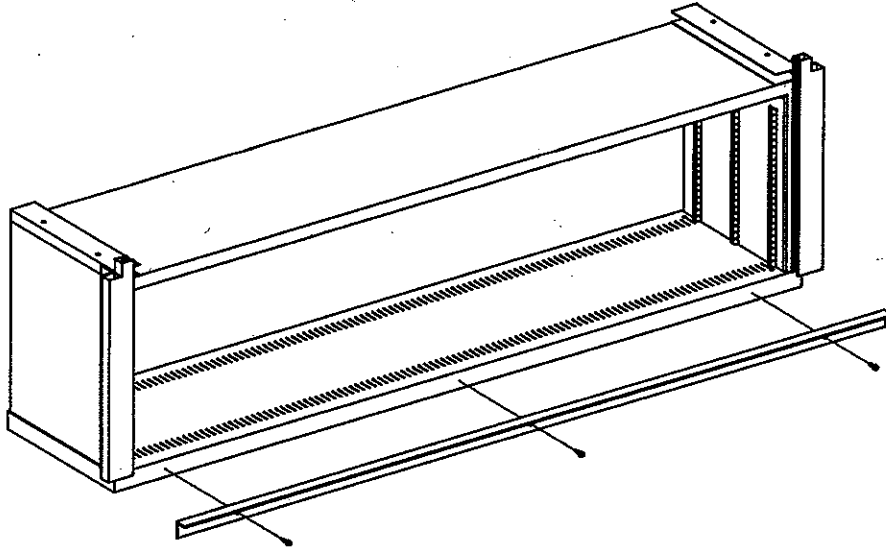

Figure 4

Step 5

Position the Door Assembly on top of the Sorter Shell by sliding the Door Feet into Left and Right Rail. Make sure the Door is also aligned with the grooves in the Left and Right Rails. **Note: This step will require two people (See Fig. 5).**

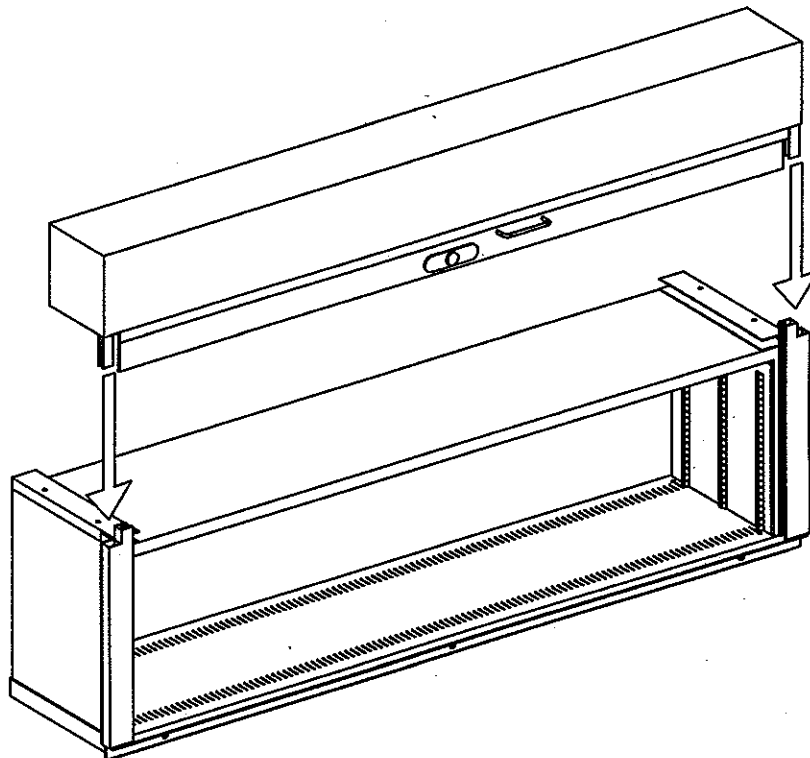

Figure 5

Step 6

- A) Determine where the first Shelf Support will be positioned by sliding a Shelf into either the left or right side of the Sorter Shell. **Note: You can work from left to right or right to left when assembling this unit (See Fig. 6).**
- B) Next, as you hold the Shelf in place, slide a Shelf Support into the top and bottom slots. Repeat this procedure for the rest of the unit.

The assembly is complete.

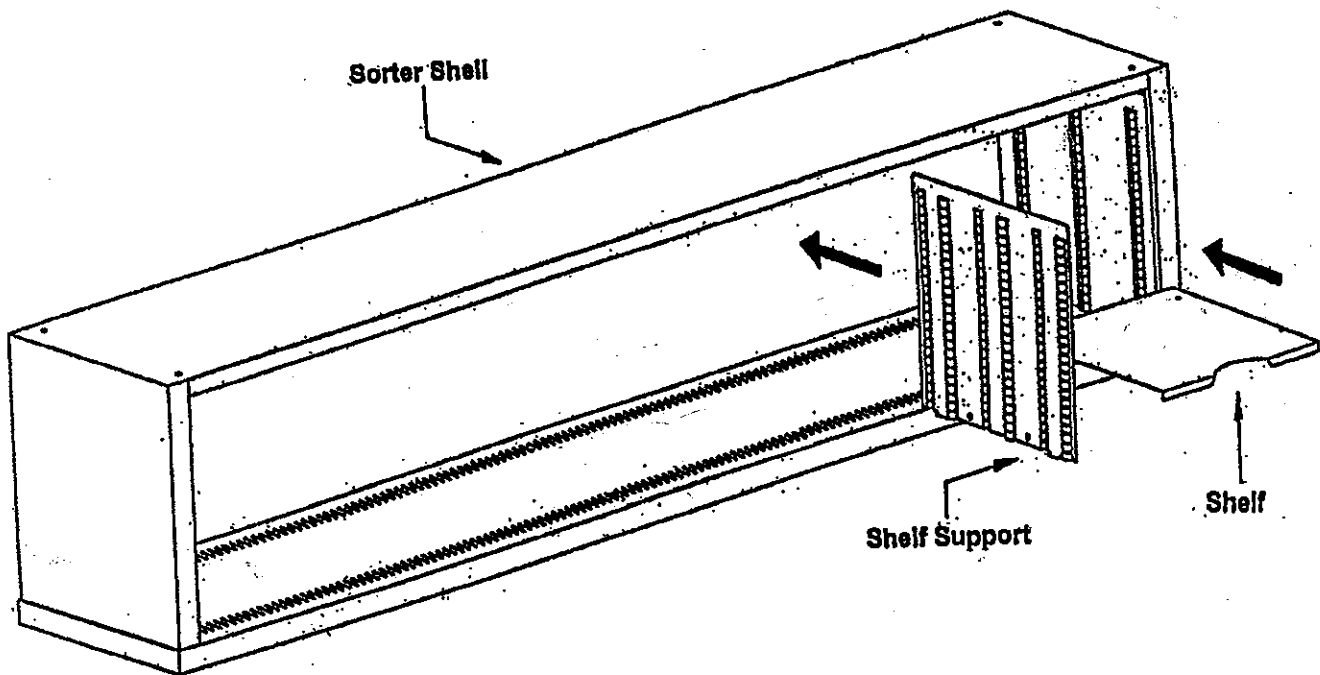

Figure 6