

SPECIFICATIONS

2-HOUR VERTICAL LETTER FILES



FIREPROOF INSULATION is Thermocell II, reinforced by a 1" by 2" lattice made of 14-gauge galvanized welded steel wire, providing complete peace of mind from fire, impact, or explosion.

FIELD REPLACEABLE STEEL PANELS can easily be replaced in the event that any panel is damaged.

FINISH is an environmentally-friendly electrostatic powder coating applied to all sides, including bottom. The finish is scratch-resistant, providing a lifetime quality appearance. Standard colors available include: parchment, tan, taupe, brown, black, sand, champagne, platinum, and pewter.

DRAWER BODIES are built with high sides for use with hanging folders – no additional frames are needed. Each file includes 1 follower block and one hanging folder frame per drawer.

DRAWER SUSPENSIONS are maintenance free.

DRAWER LOCKS are UL®-listed Medeco high-security key locks.

DRAWER PULLS are surface mounted to allow for extra insulation inside the drawer heads.

INSULATION BETWEEN ALL DRAWERS makes each drawer a separate insulated container.

WATER RESISTANCE means files are designed to prevent water damage resulting from sprinklers and fire hoses.

2-POSITION DRAWER CATCH allows access to certain drawers while others remain locked.

DRAWER HEADS are formed of welded steel and filled with fireproof insulation, and are field replaceable.

UNDERWRITERS LABORATORIES® (UL®) FIRE & IMPACT RATING on all file cabinets. These models carry the 2-Hour Class 350 Fire with Impact UL label. Tests include 2 hour exterior fire exposure at 1850°F, a 2000°F explosion test, and a 30 foot drop to test impact integrity.

OPTIONAL UPGRADES are available to enhance your file's appearance or functionality.

Upgrades available include custom color finishes, standard lock options, casters, and interior options such as document inserts and trays.

FIREKING'S LIMITED LIFETIME WARRANTY on all mechanical or operable parts. Associated labor costs will be paid by FireKing for two years from the date of purchase. If your FireKing file sustains any damage while protecting documents from a fire, FireKing will replace the file free of charge. For more details visit www.fireking.com.

Filing Arrangement:

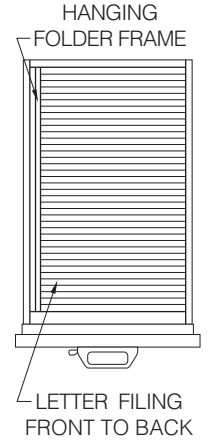

SIDE VIEW:

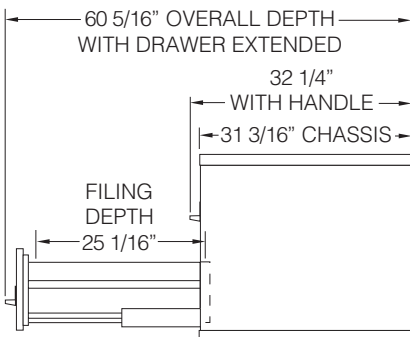

MODEL 2-1929-2:

482 lbs (avg. ship wt.)

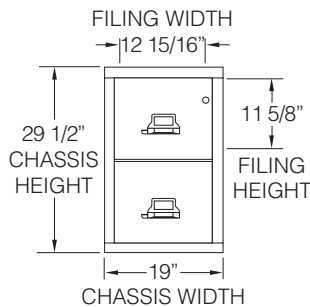

MODEL 3-1943-2:

674 lbs (avg. ship wt.)

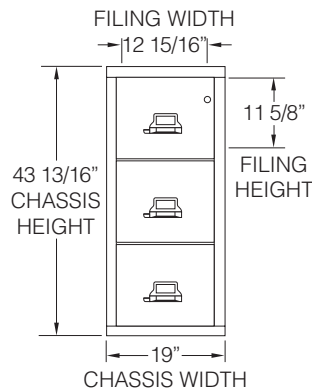

MODEL 4-1956-2:

957 lbs (avg. ship wt.)

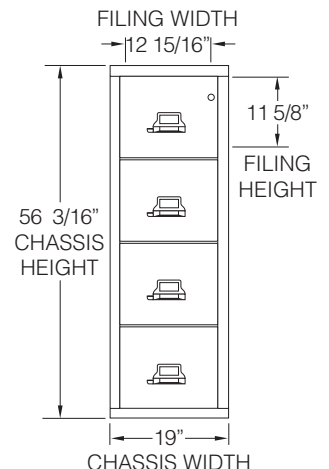

Dimensions
± 1/16 inch



American Filing Solutions
P.O. Box 891719, Temecula CA 92589
Tel: 1-951-694-4150 | 1-888-891-1970
Fax: 1-951-506-7717 | 1-888-891-9970
Email: sales@FilingToday.com
www.FilingToday.com