

FLIP AND NEST TABLE



ADJUSTABLE FLIP TOP TABLE – CRANK HANDLE STAND-NESTC-60 & STAND-NESTC-72

Luxor's new flip top table is a multipurpose sit/stand desk that's perfect for schools, training rooms, or general office use. The convenient crank handle adjusts the table height from 30" to 42.25" to accommodate a range of seated or standing users, while 3" locking casters allow easy mobility. Adding to its versatility, each table can be neatly folded for space-saving storage using two pull-handles that flip the table into a nesting position. Choose Luxor's 60" or 72" mobile flipper table to create a professional and ergonomic work space.

- Meets ANSI/BIFMA standards
- Versatile tables can be used in training, conferences, education, and business meetings
- Crank handle offers an economical choice without compromising quality
- Adjusts between 30" – 45.25" for seated and standing users
- Table is lightweight and moves easily on four 3" furniture casters (two locking brakes)
- Grommet holes route, network, and organize cables
- Easy set-up and teardown with release latches under table
- Multiple tables nest together for simple storage



Available Sizes:



American Filing Solutions P.O. Box 891719, Temecula CA 92589
Tel: 951-694-4150 | Fax: 951-506-7717 | www.FilingToday.com



INNOVATIVE WORKSPACE PRODUCT SOLUTIONS

STAND-NESTC-60 - ADJUSTABLE FLIP-TOP TABLE

Product Specifications:

Item Number	Stand-NestC-60
Dimensions	59" W x 23.6" D x 30" – 45.25" H
Table Material	Particle board with Melamine Top; PVC edge banding
Color Finish	Gray
Table Dimensions	59" W x 23.6" D x 0.17" H
Leg Material	Steel
Grommet Holes	Two; 2" diameter
Weight	91 lbs.
Adjustable Height Increments	Any height between 30" – 45.25" H
Height Adjustment Mechanism	Crank
Flipping Mechanism	Bar with two handle pulls
Casters (4)	3" furniture casters; two locking brakes
Weight Capacity	150 lbs.
Ship Method	Freight
Shipping Carton Dims	63" W x 28" D x 7" H
Shipping Weight	100 lbs.
Meets ANSI/BIFMA	Yes
Assembly Required	Yes

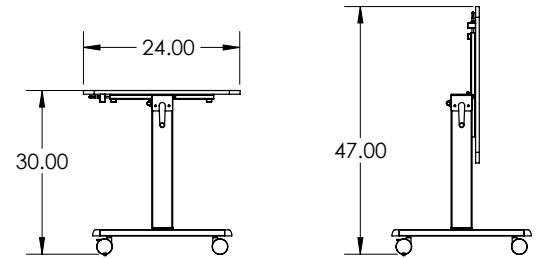
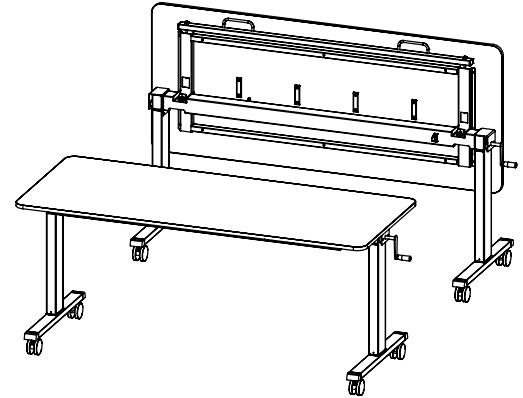

To Order, Call Your Sales Representative at 951-694-4150