

ASSEMBLY INSTRUCTIONS SPLIT TOP RANGER TABLE

CATALOG No:
7772 7773
7772A 7773A

NOTE: Please count and inspect all pieces before disposing of any carton or packing materials.

When ordering components, specific color information may be required.
Contact a Mayline Customer Service Representative. 1-800-822-8037

COMPONENTS:

*** Denotes Color Code*

TABLE

REF. #	QTY.	DESCRIPTION	PART No.
1	1	R.H. END ASSEMBLY	A7560**
2	1	L.H. END ASSEMBLY	A7559**
3	1	FRONT RAIL	B7650**
4	1	REAR RAIL	B7189**
5	1	FOOT RAIL	B2026**
6	1	DUST COVER	L4540
7	1	'H' FRAME	A4011**
8	2	SUPPORT RAIL	B6543**

OPTIONAL COMPONENTS:

The following components are in addition to the TABLE components.

*** Denotes Color Code*

TOOL DRAWER ACCESSORY:

9	1	CENTER SUPPORT	B7469**
10	2	DRAWER SLIDE	B6361
11	1	TOOL TRAY	F187
12	1	TOOL DRAWER	A7553**

HARDWARE BAG

Part No. A7683 Ranger

Part No. A7684 Ranger with OPTIONAL Tool Drawer

TABLE *for individual item, order that part number

REF. #	QTY.	DESCRIPTION	PART No.
E1	2	LOWER HINGE	B195*
E2	2	UPPER HINGE	B194*
E3	8	10-24 x 3/8 SCREW	X147*
E4	8	10-24 KEPS NUT	T2*
E5	12	1/4-28 x 3/8 SCREW	X156*
E6	12	1/4-28 KEPS NUT	T25*
E7	10	8 x 5/8 SCREW	X140A*
E8	18	10 x 3/4 SCREW	X11*
E9	2	BUMPER	D10*
E10	2	LIFT ASSEMBLY	V120A*
E11	4	10-32 x 1/2 FLAT HEAD SCREW	X191*
E12	10	10-32 x 1/2 PAN HEAD SCREW	X204*

OPTIONAL COMPONENTS HARDWARE:

The following hardware is in addition to the Table Hardware .

TOOL DRAWER ACCESSORY:

E13	6	10-24 x 3/8 SCREW	X147*
E14	4	10-24 KEPS NUT	T2*
E15	1	HANDLE	Q35*
E16	6	8-32 x 3/8 THRD. CUTTING SCREW	X247*
E17	6	8-32 x 5/16 MACHINE SCREW	X384*
E18	6	8-32 ACORN NUT	T129*

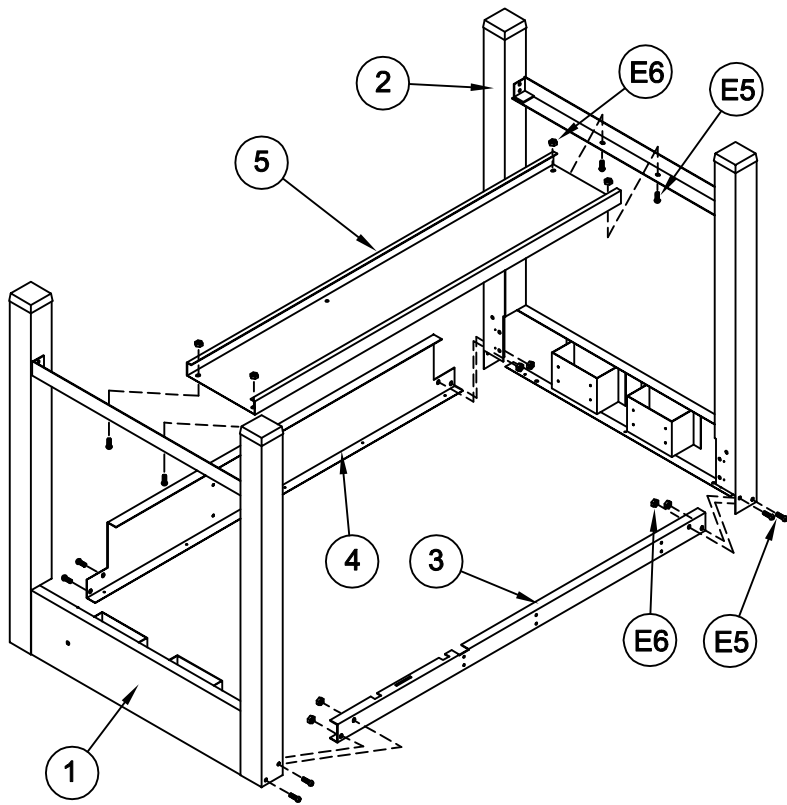

1. Place the two End Assemblies (1 & 2) upside. Position the Front Rail (3) with notches 'UP'. Position the Rear Rail (4) with the Dust Cover attachment holes toward the floor. Secure these Rails to the End Assemblies with two Screws (E5) and two Nuts (E6) per end. DO NOT tighten screws at this time.

2. Position the Foot Rail (5) with flat surface toward the floor. Attach the Foot Rail to the End Assemblies with four Screws (E5) and Nuts (E6). TIGHTEN all rail attaching screws now.

3. Turn assembled table to an upright position. MAYLINE recommends that two people perform this task.

4. Attach the Support Channels (8) to the 'H' Frame (7) using #10-32 x 1/2 Screws (E12). Position the Frame with the diagonal holes for the top hinge attachment to the front. Position each Support Channel with the 7/8 notch to the front. Frame should be flush with the top of the Support.

5. Place the 'H' Frame/Support Assembly into position and attach it to the Front and Rear Rails using #10-24 x 3/8 Screw (E3) and KEPS Nuts (E4).

6. Attach Lower Hinge (E1) to 'H' frame with #10-32 x 1/2 Thread Cutting Screw (E12). Position with hinge slot toward front of table.

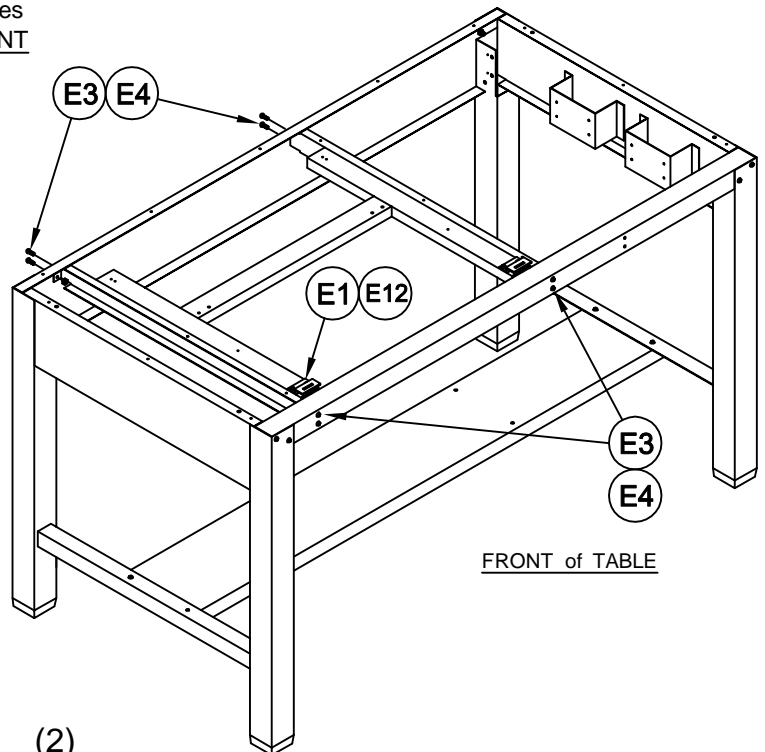
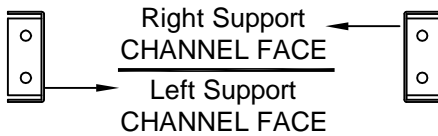
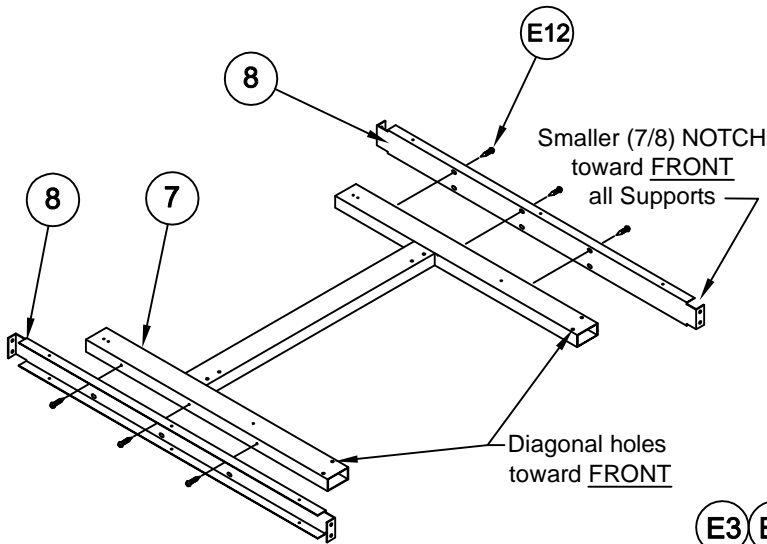

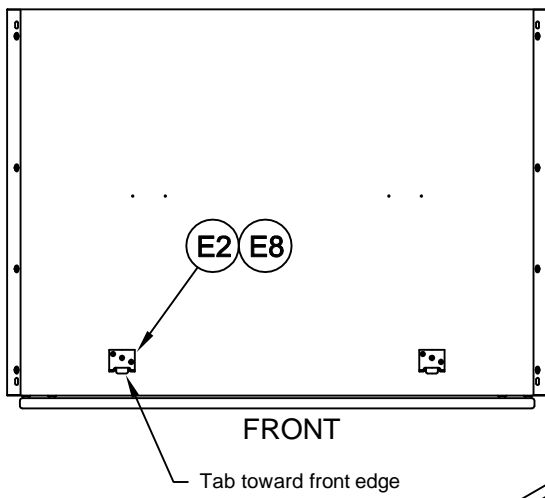

7. Attach the Upper Hinges (E2) to the underside of the Tilt Top with #10 x 3/4 Particle Board Screws (E8). Position with the hinge tab toward the front edge of the top.

8. Attach Lift Assembly (E10) to the 'H' Frame cross rail with #10-32 x 1/2 Flat Head Screws (E11).

9. Install the Tilt Top onto the table. Insert the upper hinge tab into the slot of the lower hinge. Raise the Lift Assembly and align the holes in the lift with the holes in the top. Attach with #10 x 3/4 Particle Board Screws (E8).

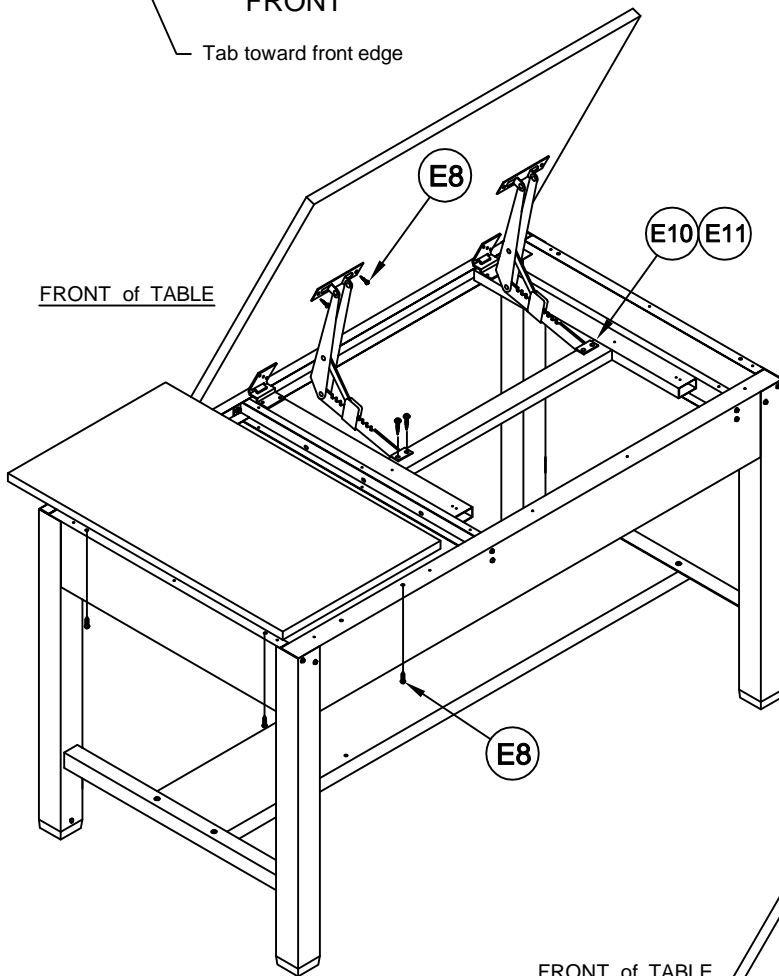

10. Attach the Reference Top to the base with #10 x 3/4 Particle Board Screws (E8) through the front and rear rail and through the side flange.

11. Attach Dust Cover (6) to base with #8 x 5/8 Screws (E7).

12. Attach top Bumpers (E9) to Dust Cover with #10 x 3/4 Screw (E8). Position approximately as show. Measured from edge of dust cover.

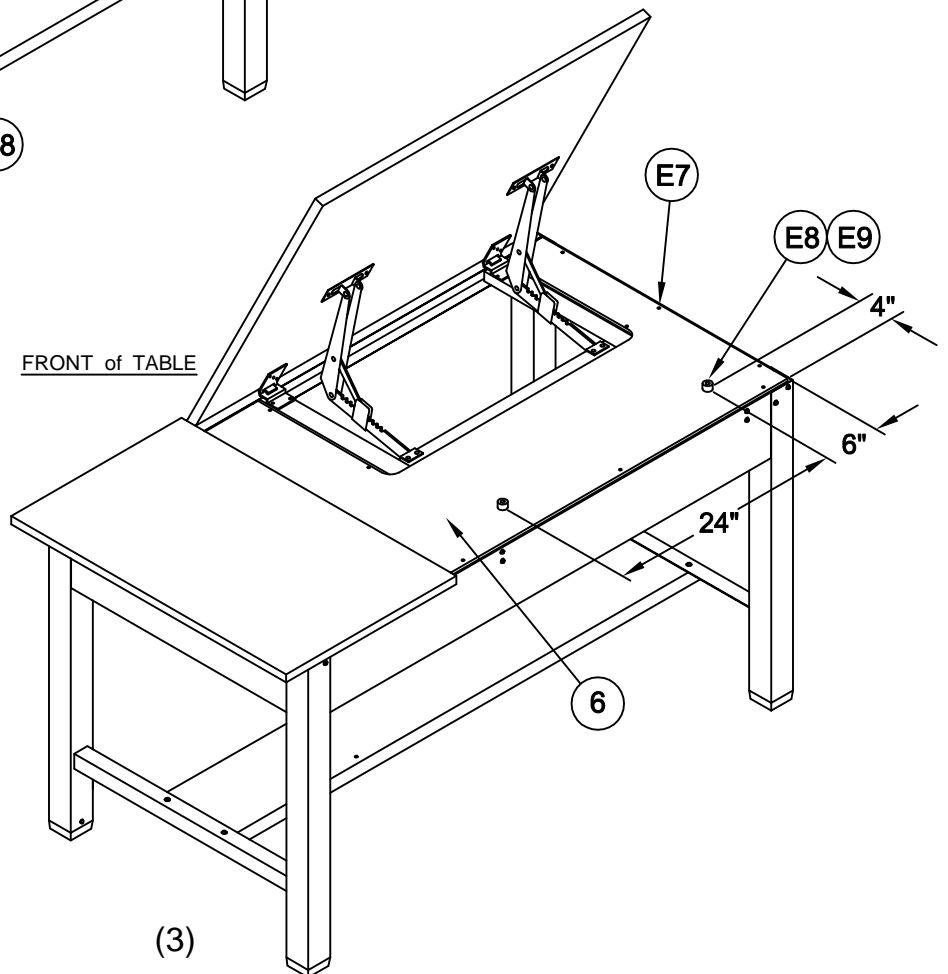

ASSEMBLY INSTRUCTIONS: OPTIONAL TOOL DRAWER

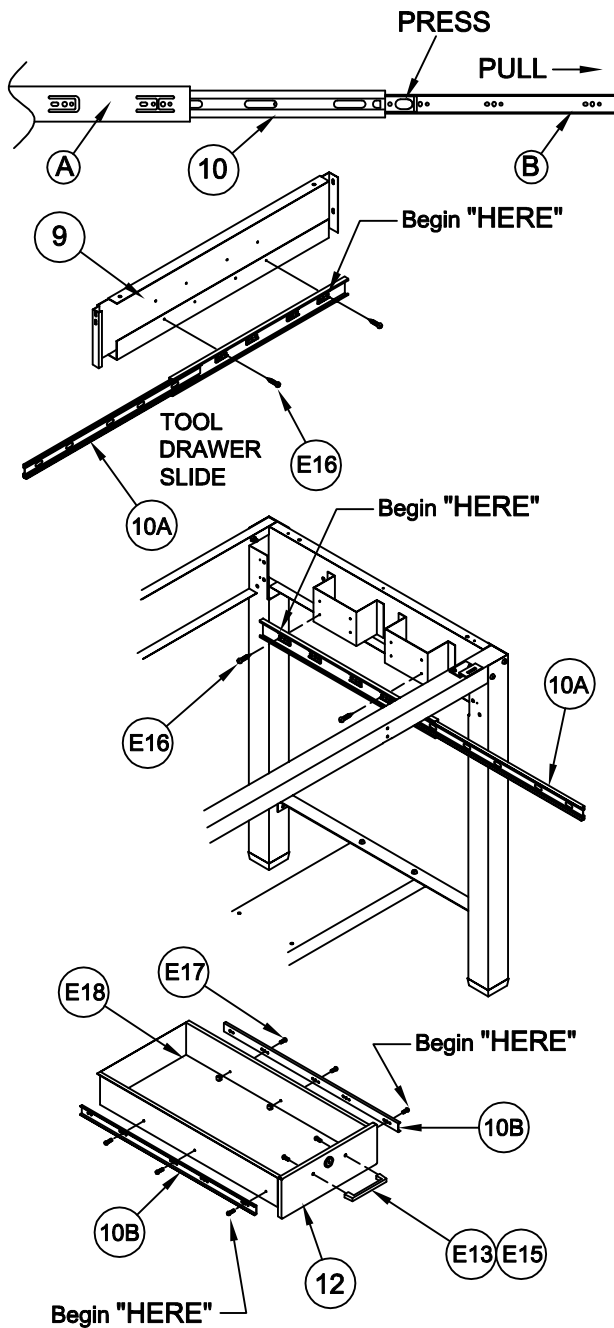

1. Separate the Drawer Slides (10) into two pieces. Extend the Slide to the full extension. Remove the smaller portion (10B) by pressing the plastic release and pulling.

2. Attach the large Slide portion (10A) to the Center Support (9) using two Screws (E16). Begin attaching the Slide using the large 'Horizontal' slot in the last mounting tab.

3. Attach one large Slide portion (10A) to the brackets on the R.H. side of the table using two Screws (E16). Begin attaching the Slide using the large 'Horizontal' slot in the last mounting tab.

4. Attach the smaller Slide portion (10B) to each side of the Drawer body using three Screws (E17) and three Acorn Nuts (E18). Begin attaching the Slide using the 'Vertical' slot in the first hole cluster.

5. Install the Handle (E15) onto the Tool Drawer head using Screws (E13).

6. Install the assembled Center Support into the Base. Attach the Support with two Screws (E13) and two Nuts (E14) per rail.

7. Install the drawer into the assembled table.

