

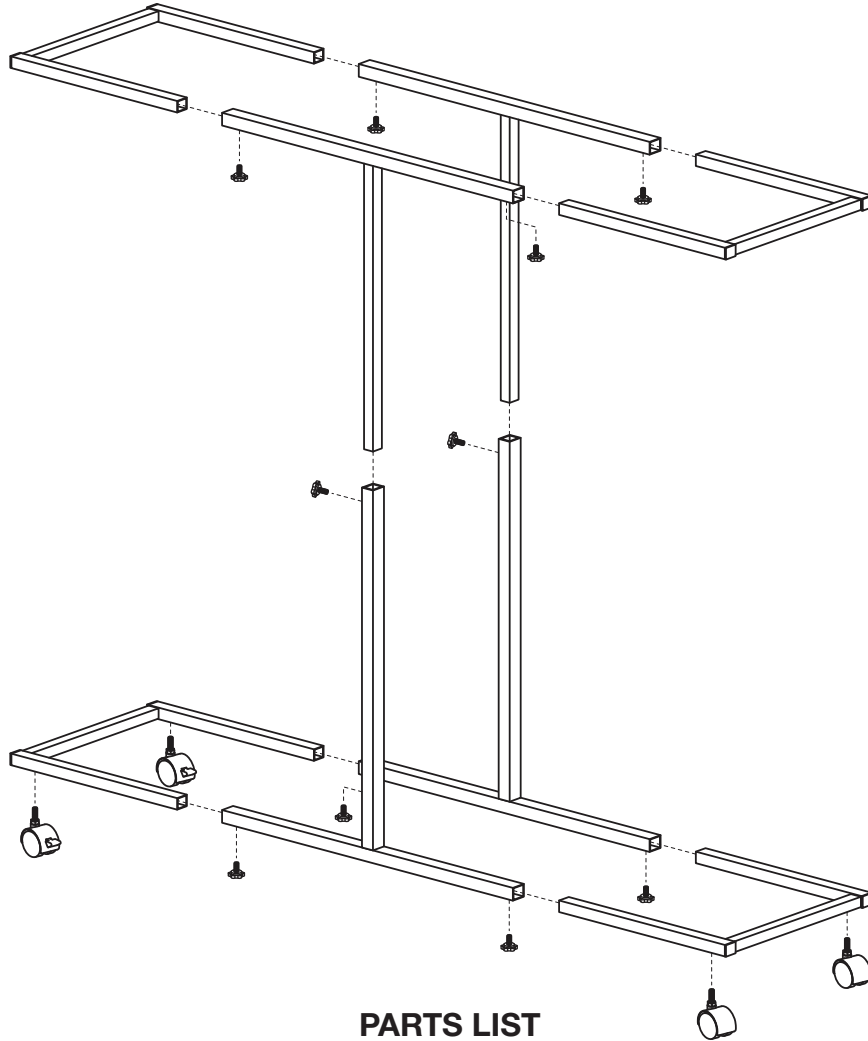





## Assembly Instructions

for MODEL **614**

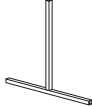
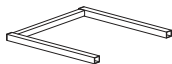
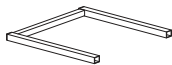

### PARTS LIST

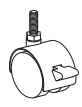
Item	Description	QTY.
A	 Upper T- Frame Has "2" holes for setting knobs	2
B	 Lower T-Frame Has "3" holes for setting knobs	2
C	 Upper U-Frame	2
D	 Lower U-Frame Has holes for casters	2

Item	Description	QTY.
E	 Setting Knob	10
F	 Locking Caster	2
G	 Caster	2
H	 End Cap	8
I	Wrench	1

Tools required for assembly: **Phillips screwdriver**

## Assembly Instructions

for MODEL **614**

- Slide lower U-Frames (part D) into Lower T-Frames (Part B) Making sure that holes for casters are facing down. Adjust to clamp size. Insert setting knobs (Part E) into sockets and tighten.

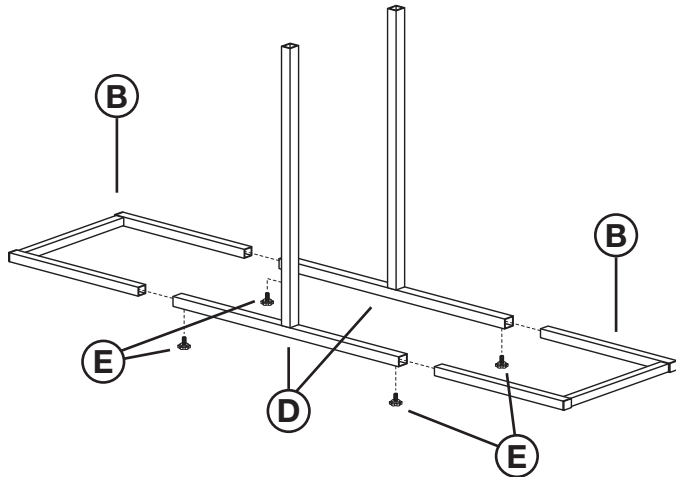

- Insert casters (Parts F&G) into holes of lower U-Frames. Attach locking casters to same U-Frame.

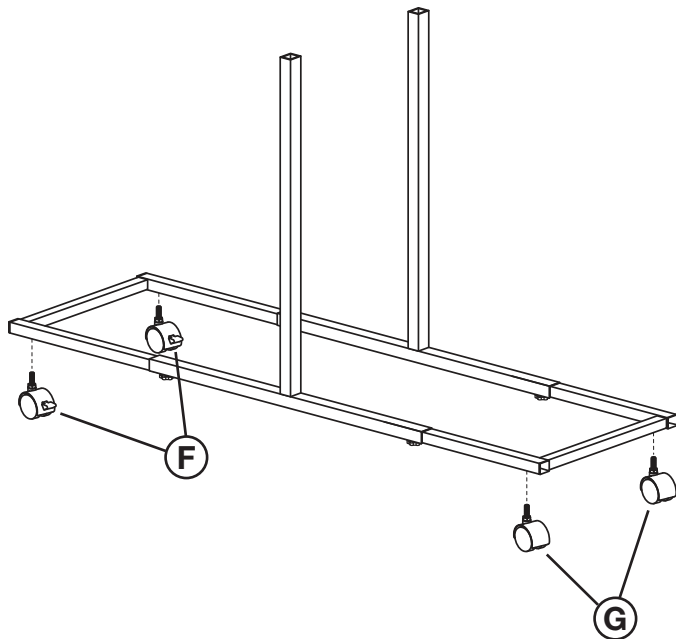

- Slide upper U-Frames (part C) into upper T-Frames (part A). Adjust to clamp size. Insert setting knobs (Part E) into sockets and tighten.

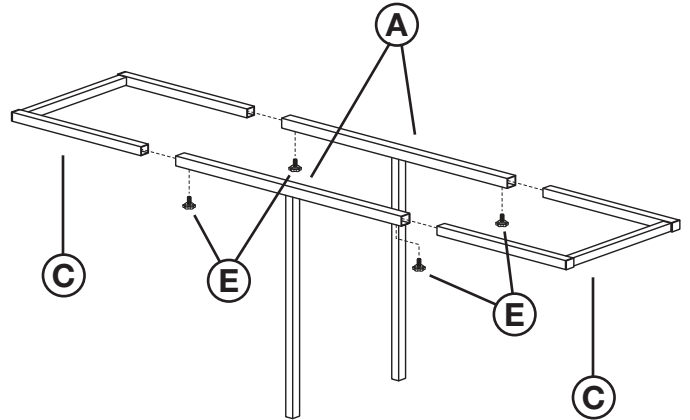

- Slide Upper Frames into Lower Frames. Adjust to paper size. Insert setting knobs into holes and tighten.

