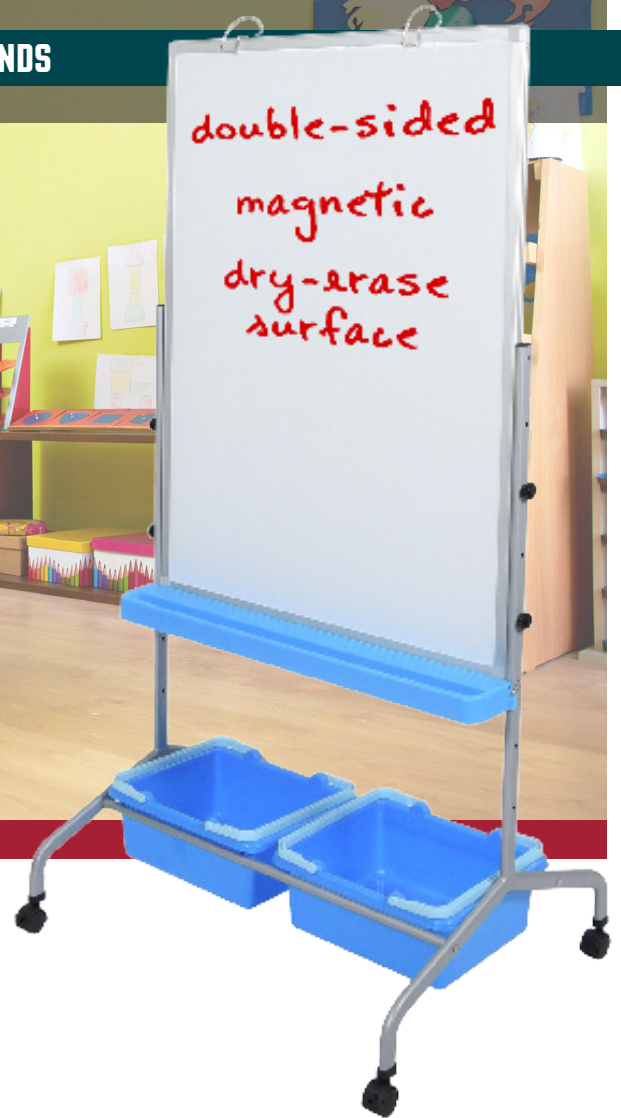

CHART STANDS



CLASSROOM CHART STAND WITH STORAGE BINS L330

Luxor's Classroom Chart Stand is a multiuse teaching easel that aids classroom activities throughout the school day. Teachers can readily transition students from group activities and individual work to class instruction using the magnetic two-sided dry erase boards. Instructors may also use two metal clips to hold easel paper pads and pocket charts. The height adjusts to fit multiple grade levels and locking casters ensure smooth transport from one learning area to another. Two open storage totes with convenient handles provide a place for markers, books, and other classroom items. Enhance your learning environment with this classroom easel stand!

- Double-sided magnetic whiteboard is well suited for group and individual activities, or a teacher's instructional board
- Two durable plastic open bins hold supplies while handles allow for easy toting
- Chart hooks display easel paper pads, pocket charts, and posters
- Dry-erase magnetic whiteboard will never stain or ghost
- Four casters can move board throughout the classroom and lock firmly into place
- Marker ledge holds books and stores whiteboard materials

Two open storage totes
with handles

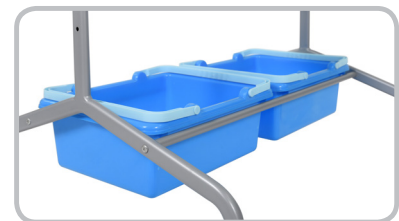

Hold easel paper pads and
pocket charts



American Filing Solutions P.O. Box 891719, Temecula CA 92589

Tel: 951-694-4150 | Fax: 951-506-7717 | www.FilingToday.com



[www.FILING
TODAY.COM](http://www.FILINGTODAY.COM)

INNOVATIVE WORKSPACE PRODUCT SOLUTIONS

L330 - CHART STAND

Product Specifications:

Item Number	L330
Frame Material	Painted Steel
Frame Dimensions	31" W x 25" D x 53" – 69" H
Height Increment	4"
Board Make	Magnetic Painted Steel
Board Dimension	30" W – 40" H.
Tray Make	Plastic
Tray Dimensions	31" W x 4" D
Bins Make (2)	Plastic (PP)
Bin Inside Dimensions	10.25" W x 5" D x 12.75" H
Weight	20 lbs.
Casters	2" furniture casters; two locking brakes
Weight Capacity	20 lbs.
Ship Method	Ground
Shipping Carton Dims	2 cartons; Ctn. 1: 49" W x 38" D x 4" H; Ctn. 2: 15" W x 16" D x 9" H
Shipping Weight	Ctn. 1: 27 lbs.; Ctn. 2: 4 lbs.
Assembly Required	Yes

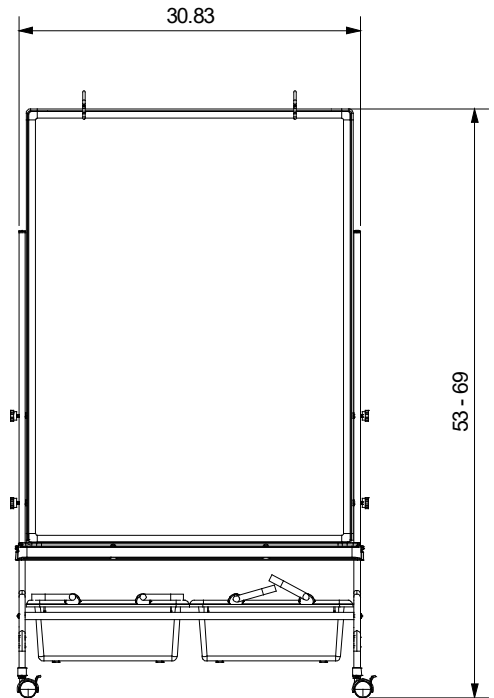
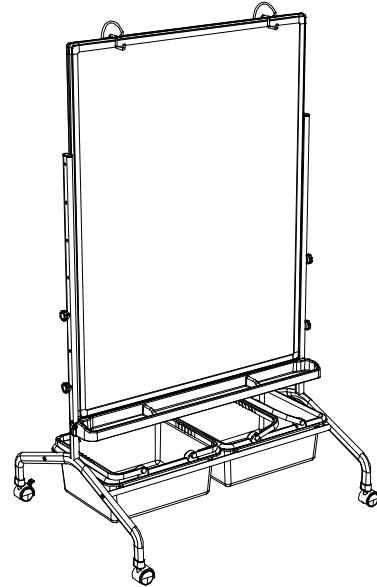

**To Order, Call Your
Sales Representative at
951-694-4150**