

STEP #1: GLIDE ASSEMBLY

- 1) Assemble a threaded glide to each of the legs.

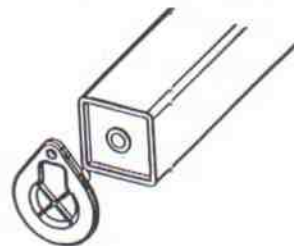

STEP #2: CONNECTING FRAME HALVES

- 1) Position frames on legs and align bolts holes in table angles. (see Fig. 1)
- 2) Fasten together using 1/4"-20 x 3/4" bolts and 1/4"-20 nuts.
- 3) Level table angles and then tighten nuts.

Note If tables wider than 24" are required, or if additional belly room is needed: Installed expansion spacer as shown. See layout for additional information.

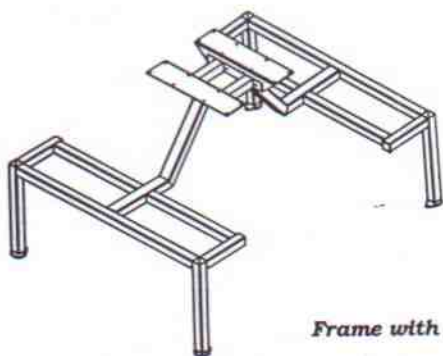
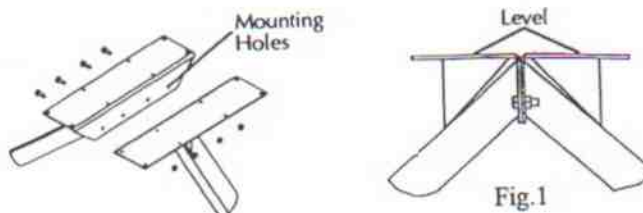

Frame with expansion spacer

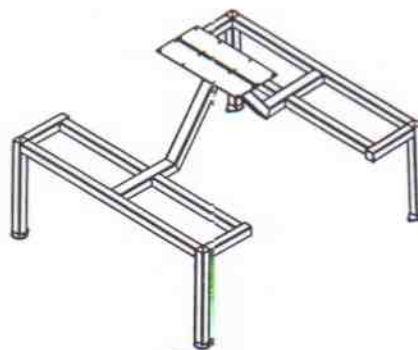
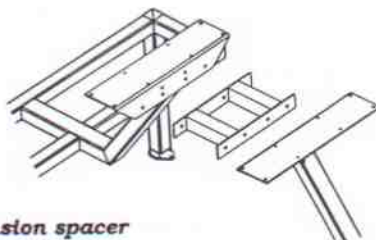

STEP #3: ATTACHING SEATS TO FRAME

- 1) Locate seat fastening hardware. (flat bench rear hooks 4 per seat)
- 2) Place seat atop frame.(flat bench)
- 3) Center seat on frame. (right to left)
- 4) Insert short tongue of rear seat hook into seat plate. Using screwdriver snap hook to frame as shown. (See fig. 2) Steps 5-7 pertain to contour seats only
- 5) Position seat on end as shown. (fig 3)
- 6) Insert short tongue of front seat hook into seat plate.
- 7) Position seat over frame, tip front edge of seat forward and pull seat into place.
- 8) Attach elbow bolts to front seat hooks and hand tighten 1/4-20 nut.
- 9) Insert short tongue of rear seat hook into seat plate as shown. Using screwdriver snap hook to frame as shown. (See fig. 2)
- 10) Tighten 1/4-20 nuts on front seat hooks.

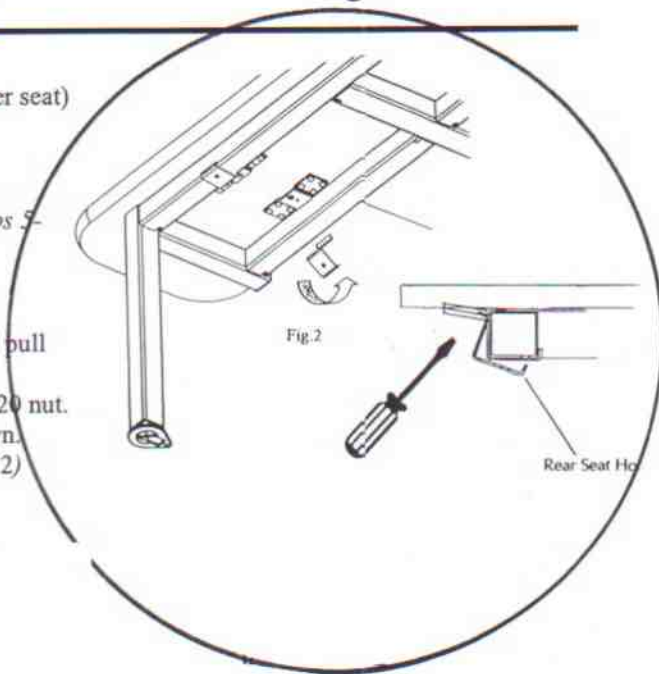

STEP #4 FASTENING TABLE -TOPS

- 1) Locate and mark centerlines on the bottom surface of the tabletop. (see fig. 3)
- 2) Align your centerlines on tabletop with joint of frame halves. (see fig. 4)
- 3) Secure the tabletop using #10 x 1" pan head sheet metal screws.

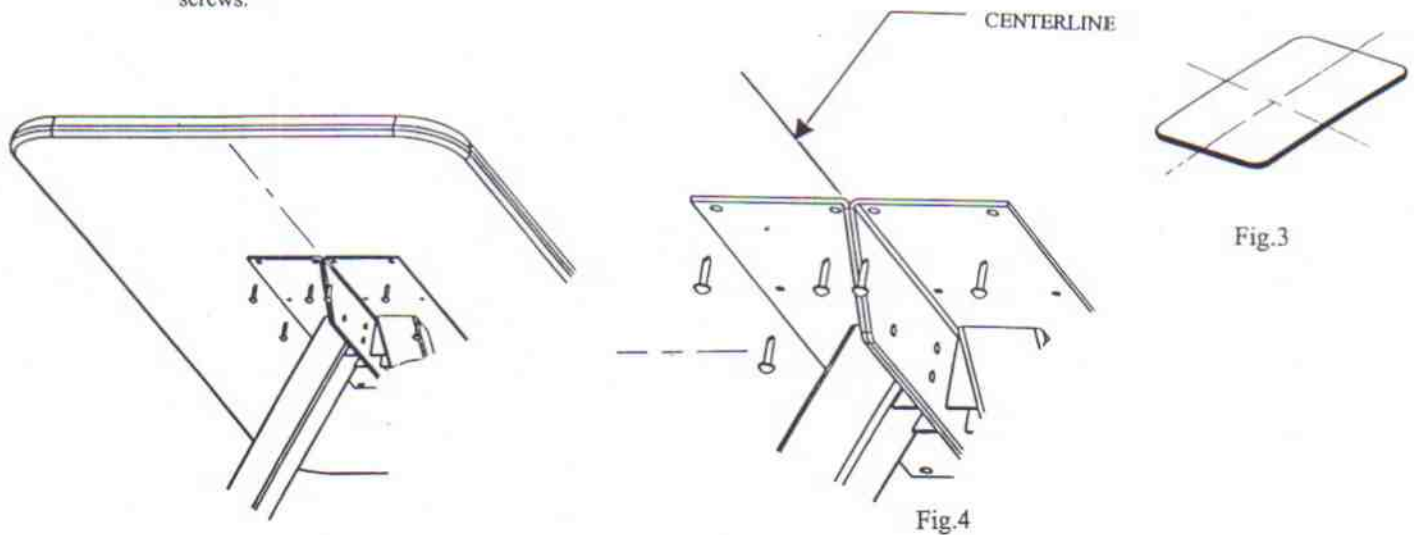

STEP #5: POSITIONING AND LEVELING

- 1) Confirm location of frames with floor plan.
- 2) Level booths by adjusting thread-in glides.
- 3) Fasten each glide to the floor using the floor anchors and #10 x 1" pan head sheet metal screws.



Note Frames must be anchored to the floor to maintain stability and prevent personal injury.

STEP #6: FASTENING GLIDES TO FLOOR

- 1) Rotate glides so that the mounting hole is pointing towards the center of the booth.
- 2) With a pencil/pen, mark the hole location on the floor using the hole in the glides.
- 3) Turn the glide away 90 degrees from its current position to expose the mark on the floor.
- 4) Using a hammer drill and a 1/4" masonry bit, drill a 1 1/4" deep hole on the pencil mark.
- 5) Place a plastic anchor in the hole, rotate the glide back and align the holes.
- 6) Insert a #10x1.00" screw through glide and secure to floor.

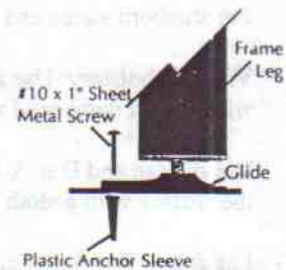

STEP #7: CARE

- 1) Clean furniture and protect until ready for use



American Filing Solutions
P.O. Box 891719, Temecula CA 92589
Tel: 1-951-694-4150 or 1-888-891-1970
Fax: 1-951-506-7717 or 1-888-891-9970
Email: sales@FilingToday.com
www.FilingToday.com