

STAK-N-LOK™ ASSEMBLY INSTRUCTION SHEET

Open boxes and check to make sure you have all pieces needed before starting to assemble

*****PLEASE READ ENTIRE ASSEMBLY SHEET BEFORE STARTING*****

TOOLS NEEDED FOR ASSEMBLY: Hammer, Level & 7/32" Nut Driver

TOOLS PROVIDED (Starter Units only) in plastic hardware bag: 3/32" Allen wrench, 4 Drive Rivets and 2 Allen screws (and one spare).

TOOLS PROVIDED (Add-on Units only) in plastic hardware bag: 3/32" Allen wrench, 2 Allen screws & 8 Drive Rivets.

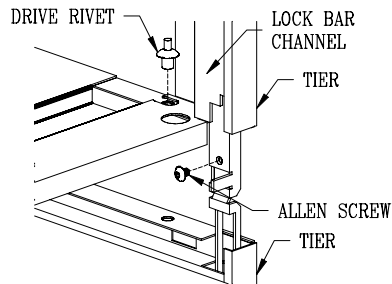
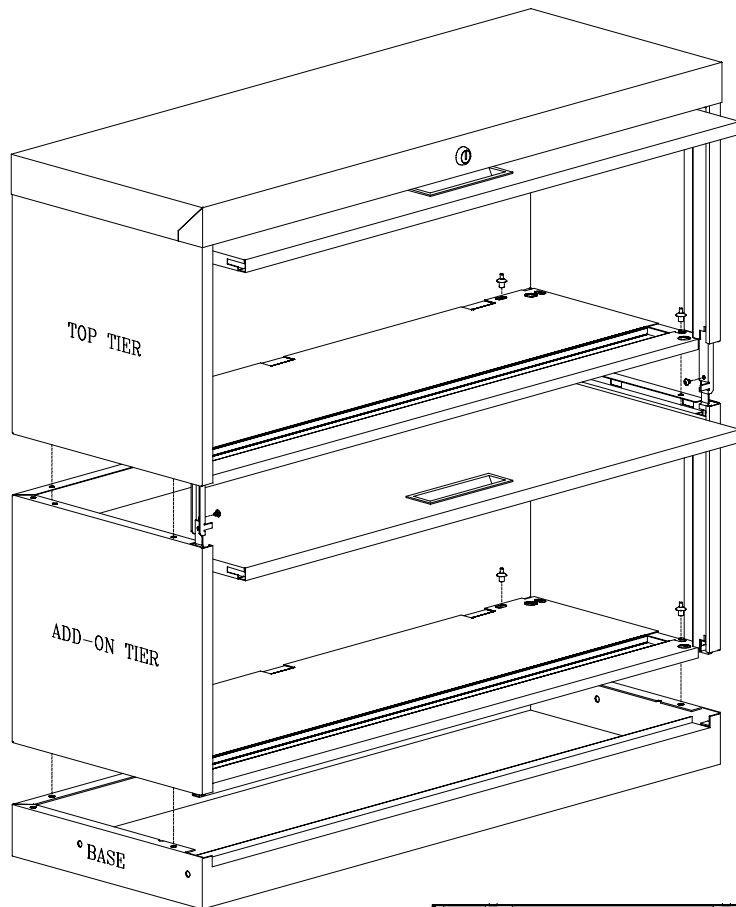

Fig. 1

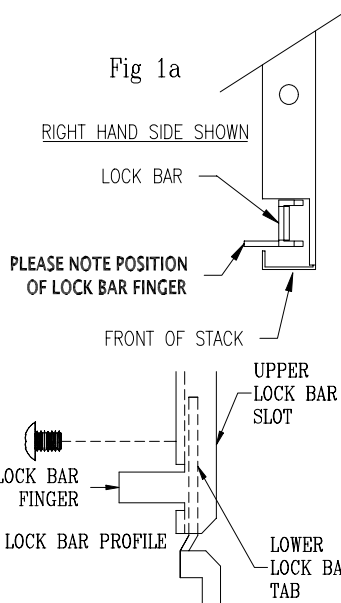
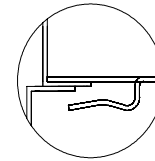

Fig 1a



INTERLOCKING TABS

Fig. 4

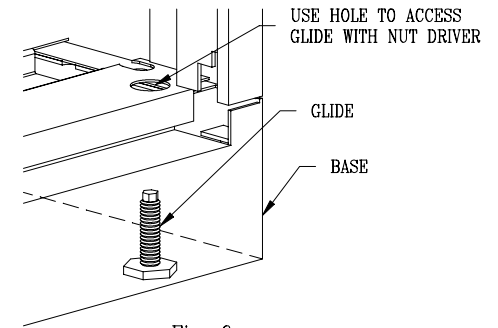

Fig. 6

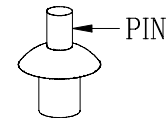
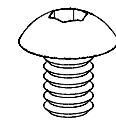

Fig. 5

DRIVE RIVET



ALLEN SCREW

A.)

- 1 As you face the base, make sure the side with the lower lip is in the front; lip with holes in rear.
- 2 Insert the two (2) lock bars (see Fig. 1a) into the lock bar channels going from the underside of the tier up. Make sure lock bar finger faces toward front of tier (Fig. 1).
- 3 Position tier on top of base sliding tier towards the back. Be sure that the three INTERLOCKING TABS on the bottom of the tier hook under the rear lip of the base (Fig. 4). All sides must be flush. Be careful not to let lock bars fall out of lock bar channels.
- 4 Align the small holes in the tier bottom with the corresponding holes in the base and insert **FOUR ONLY** drive rivets (pin side up) in the holes using the hole pattern shown in Fig. 3. Use a hammer to drive rivet pins into the body of the rivets until pins are flush with the

B.)

- 1 Remove next add-on tier and hardware kit from shipping box. From bottom of tier insert the two (2) lock bars into the lock bar channels as done previously in step A2. Carefully position tier on top of previous tier. Slide tier towards back of unit so the three INTERLOCKING TABS on the bottom of the tier hook under the rear lip of the tier below.
- 2 Lift up the front of the add-on tier and position it so that the lower lock bar tab fits inside the upper lock bar slot (Fig. 1) on both left and right sides. Fasten lock bars together using the Allen screws and Allen wrench provided in the hardware bag (Figs. 1).
- 3 Insert rivets in holes as described in instructions A3 above.
- 4 Repeat the above steps until all tiers are assembled. The tier with the lock (in Starter Unit carton) must be assembled as the top or last tier.

C.)

- 1 For doors to operate smoothly, Stak-N-Lok™ tier sections must be leveled. Place level on top of top most tier. Using a 7/32" nut driver, raise or lower the leveling glides (see Fig. 6) until the unit is level front-to-back and side-to-side.

To add tiers to existing units, see back of this sheet.

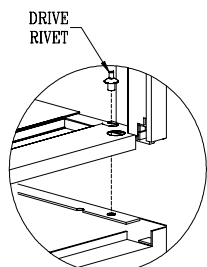
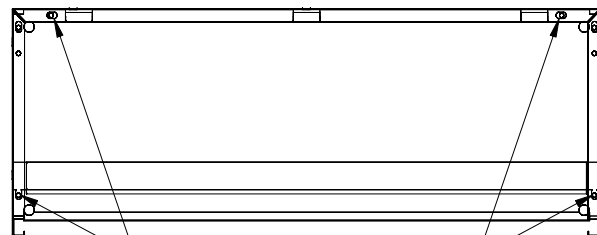

Fig. 2



INSTALL 4 DRIVE RIVETS HERE

Fig. 3

ADDING TIERS TO EXISTING UNITS

If adding a tier to an existing unit, you must remove the top tier (*tier with lock*) and insert the add-on tier beneath it. To accomplish this, the four drive rivets which fasten the existing top tier in place must be removed and the lock bar temporarily disconnected.

1. **Removing Drive Rivets (Fig. 2):** Using either a nail or a nail punch along with a hammer, drive the rivet pin (Fig. 5 on previous page) all the way down and through the drive rivet until it drops out. With the nail or nail punch in the hole, pry the rivet out.
2. **Disassembling Lock Bars (Fig. 1):** Using the Allen wrench provided, remove the Allen screws located on both the left and right side lock bars and set aside for re-assembly later. Now, lift up the tier in the front, slide towards you and set aside.
3. Follow steps B1 through B4 and C1 shown on the other side of this page for the assembly of the add-on tiers.

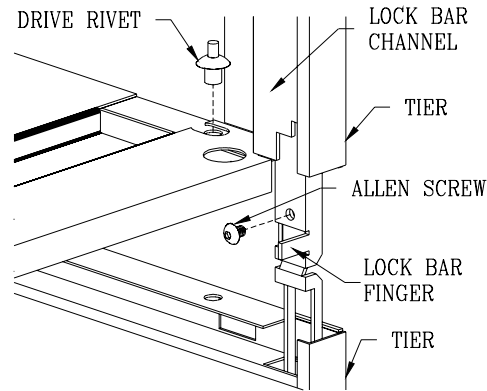
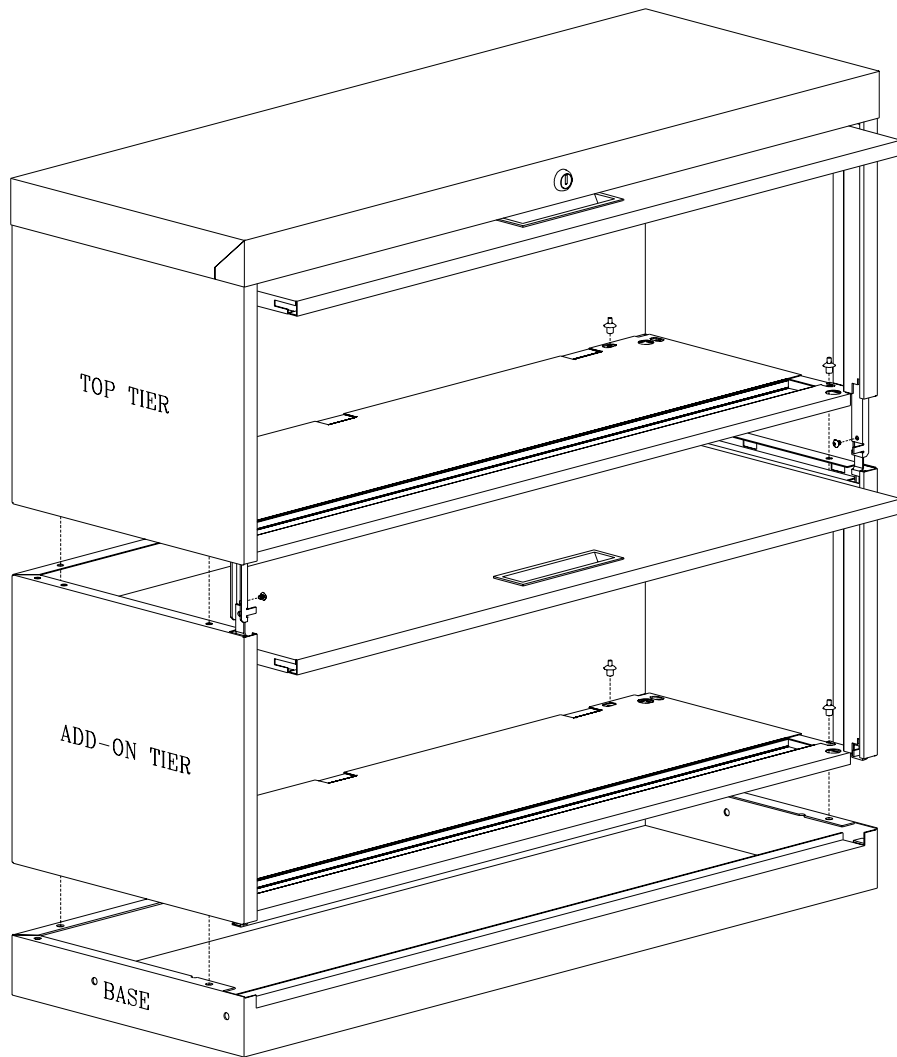

Fig. 1

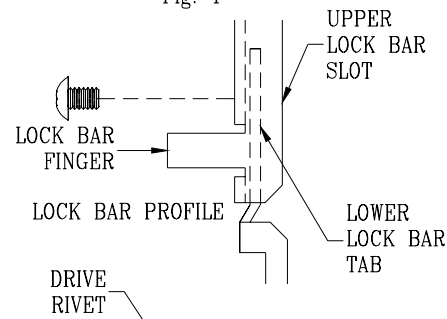

Fig. 2